

# Industrial RS-232/RS-485/RS-422 Converter



**Part Number: CVT-485\_422-1**



## INTRODUCTION

The CVT-485\_422-1 is a compact, rugged, industrial-grade, port-powered, bi-directional RS-232 to RS-485 / RS-232 to RS-422 converter, which can be used to convert any standard RS-232C port into a two-wire half-duplex RS-485 port, or a four-wire full-duplex RS485/RS422 port and vice versa. The unit is powered from the RS-232 data line; it also supports data direction auto-turnaround. Therefore, no external power, software drivers or flow control is required.

## FEATURES

- Industrial grade enclosed in a rugged, rustless ABS housing.
- Port-powered, no external power is required.
- Accepts external 5VDC regulated power if the port power is insufficient.
- Plug and play; Data direction auto-turnaround, no software drivers or flow control is required.
- Operating temperature: -40°F to 185°F (-40°C to 85°C).
- Built-in 600W surge protection, 15kV static protection and circuit protection.
- Built-in 120Ω end-of-line terminator for reliability and easy installation.
- Surface Mount Technology manufactured to RoHS and ISO-9001 standards.
- Safety: Strictly certified by TUV (Cert No. SG-CE-090012) / 5-year manufacturer's warranty.

## SPECIFICATIONS

Compatibility:	EIA/TIA RS-232C standard and RS-485/RS-422 standard
Power Source:	Port power from RS-232 data line
Current Consumption:	Less than 10mA
Baud Rates:	300 to 115,200bps (auto-sensing and self-adjusting)
Distance:	RS-232 side: 16ft (5m); RS-485/RS-422 side: Depending on power from RS-232 port, will transmit up to 4000ft (1.2km) at 19,200bps
Connector:	RS-232 side: DB-9 Female; RS-485/RS-422 side: DB-9 Male; Termination Board: DB-9 Female and a 6-Way Terminal Block
Maximum number of drops:	128
End-of-Line Terminator:	120Ω (Built-in)
Surge Protection:	600W
Static Protection (ESD):	Up to 15KV
Dimensions (H x W x D):	0.63 x 1.3 x 3.5 in (16 x 32 x 90 mm) (with termination board)
Weight:	1.4 oz (40 g) (with termination board)
Operating Temperature:	-40°F to 185°F (-40°C to 85°C)
Operating Humidity:	Up to 90% RH (no condensation)

## PIN ASSIGNMENT

RS-232 Side (DB-9 Female Connector):

DB-9 Pin:	1	4	6	7	8	2	3	5
Function/Internal Wiring:	tied together			tied together		TX	RX	GND

RS-485/RS-422 Side (DB-9 Male Connector / Termination Board):

DB-9 Pin:	1	2	3	4	5	6	7	8	4
Jumper:	J2 (default: ON)		J3 (default: ON)			J1 (default: ON)		J4 (default: ON)	
RS-485:	A+ (J2 ON)		B- (J3 ON)		GND	(J1 ON)		Terminate/remove Jumper J4 to turn ON/OFF the 120Ω end-of-line terminator	
RS-422:	(J2 OFF)		(J3 OFF)		GND	(J1 OFF)			
	TX+	RX+	TX-	RX-					

Termination Board:

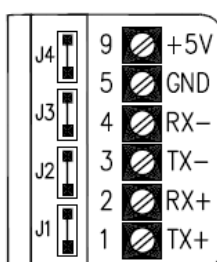

- The numbers on the left indicate the pin assignment of DB-9 male connector (RS-485/RS-422 side).
- The unit will function correctly only when the voltage on +5V pin is around +5VDC (when RS232 port is connected). Otherwise, please check the connection. External 5VDC regulated power supply is accepted.
- The unit comes with a built-in 120Ω end-of-line terminator; connect it (Jumper J4 ON) when the data rate is over 19.2kbps or the RS485/RS422's distance exceeds 660ft (200m).

## ■ CONNECTIONS

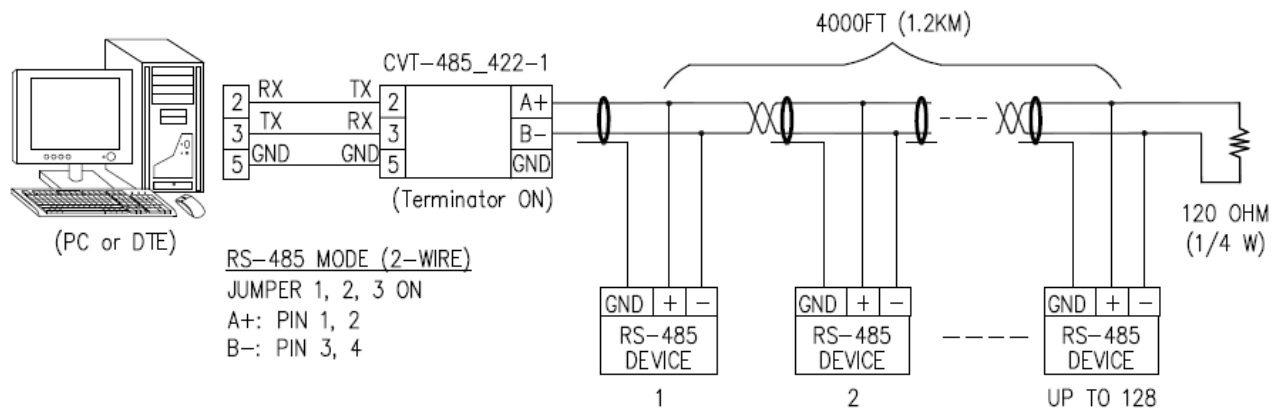

FIGURE 1: MASTER-SLAVE MULTI-DROP CONNECTIONS (RS-485)

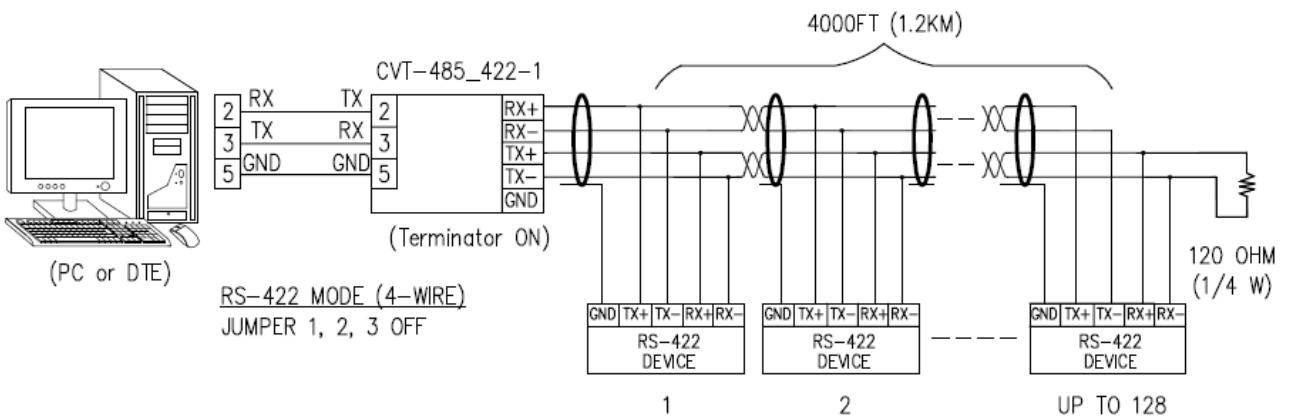

FIGURE 2: MASTER-SLAVE MULTI-DROP CONNECTIONS (RS-422)

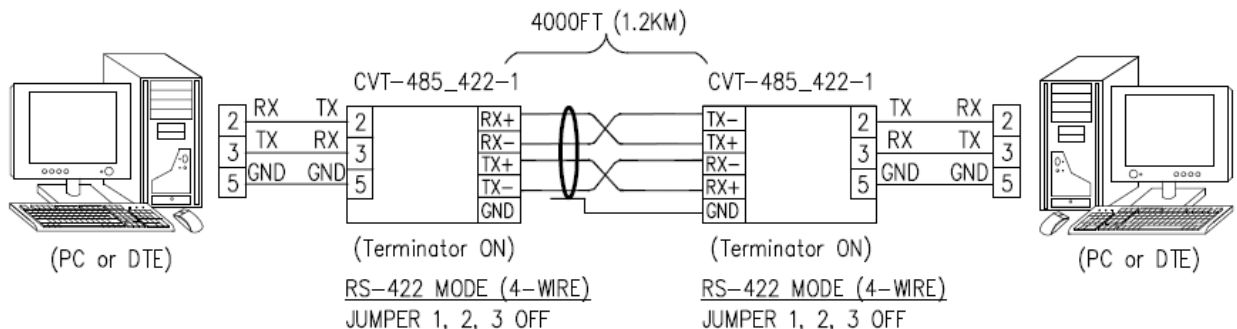

FIGURE 3: EXTENDING FULL-DUPLEX RS-232 DISTANCE (DATA ONLY)

## ■ INSTALLATION NOTES

- Connect PC's (or other DTE device's) COM port (or use a straight-through cable) to the RS-232 side of CVT-485\_422-1, use a cross-over (Null-Modem) cable for DCE device.
- 120-Ohm terminator: If you are using the converter with the provided terminal block, terminate the Jumper "J4" to turn ON the terminator and remove it to turn the terminator OFF. If you are using the converter without the provided terminal block, short pin 4 & 8 on the DB-9 connector (RS-485/422 side) to turn ON the terminator.
- The 120Ω end-of-line terminator adds heavy DC loading to a system; connect it only when the data rate is over 19.2kbps or the RS485/422's distance exceeds 660ft (200m).

## ■ TROUBLESHOOTING

- Perform a loopback test by using CommFront's 232Analyzer software: Remove jumper 1 and terminate Jumper 2 and 3, then send commands from the 232Analyzer software. You should receive an echo of the commands sent. By performing a simple loopback test like this, you can test both the transmitter and receiver of the converter. This is very helpful when you are in doubt about the performance of your converter.