



Industrial RS-232/485/422 to Fiber Optic Converter

Part Number: FBR-Serial-2 (DIN-Rail/Wall-Mount)

Single-Mode (24.8miles/40km) or Multi-Mode (1.2miles/2km)

Connector types: ST, SC or FC

CE FC

CommFront[®]
Communications made easy

[Http://www.CommFront.com](http://www.CommFront.com)

■ INTRODUCTION

The FBR-Serial-2 (DIN-Rail/Wall-Mount) is a rugged, industrial grade, multi-function serial to fiber optic converter that supports asynchronous serial communications (RS-232, RS-485, and RS-422) through fiber optic links. Besides the capability of long distance data transmission, fiber lines are inherently resistant to EMI/RFI and transient surges; therefore, they are ideal for data communications near heavy electrical equipment and other electrical or radio interference. Depending on the fiber cable and the type of converter used, a multi-mode fiber optic converter can extend the RS-232/485/422 distance to up to 1.2 miles (2 km), while a single-mode fiber optic converter can extend the RS-232/485/422 distance to up to 24.8 miles (40 km). Standards can be mixed and matched, so RS-232 devices can be connected to RS-485/422 devices, or RS-485 (2-wire) devices can be connected to RS-422 (4-wire) devices without using a converter and isolator.

The unit supports serial data rates up to 115.2kbps and features data format auto-sensing and self-adjusting, and, therefore, no DIP switch or jumpers are required. When working with RS-485 signals, the CommFront's auto-turnaround feature eliminates the need for flow control.

■ FEATURES

- Industrial grade enclosed in a rugged, rustless ABS housing.
- Direct DIN-Rail or wall/panel mounting without using any unsecured brackets or adapters.
- Standards can be mixed and matched. For instance, one FBR-Serial-2 can be configured for RS-232 while the other side can be configured for RS-485 or RS-422.
- Single or Multi-mode, with ST, SC or FC connectors.
- Transmits serial data (RS-232, RS-485 or RS-422) over long distances through fiber cables (Single-mode: 24.8 miles or 40 km; Multi-mode: 1.2 miles or 2 km).
- Supports up to 128 nodes of RS-485/422 devices.
- Operating temperature: -40°F to 185°F (-40°C to 85°C).
- Built-in 600W surge protection, 15kV static protection and circuit protection.
- Surface Mount Technology manufactured to RoHS and ISO-9001 standards.
- Safety: Strictly certified by TUV (Cert No. SG-CE-100005; SG-FCC-100002).
- 5 Year manufacturer's warranty.

■ SPECIFICATIONS

Compatibility:	EIA/TIA RS-232C, RS-485, and RS-422 standard
Power Source:	9 to 30VDC (External AC to DC power adapter included)
External AC/DC Power Adapter:	9VDC/500mA (Input: 100~240VAC 50/60Hz, US type A plug)
Current Consumption:	Less than 100mA
Serial Data Rates:	300 to 115,200 bps (auto-sensing and self-adjusting)
Wavelength:	1310nm
Usable Fiber Optic Cables:	Multi-mode: 50/125, 62.5/125µm Single-mode: 8.3/125, 8.7/125, 9/125, 10/125µm
Number of Maximum Nodes:	RS-485/422: 128 nodes
Distance (Serial Port):	RS-232: 16ft (5m); RS-485/422: 4000ft (1.2km)
Distance (Fiber Lines):	Multi-mode: 1.2 miles (2km); Single-mode: 24.8 miles (40km)
Connectors (Serial Port/Power):	Serial Port/Power: 10-way terminal block
Connectors (Fiber Links):	2x ST Connector; 2x SC Connector; or 2x FC Connector
Surge Protection:	600W
Electro-Static Discharge (ESD):	Up to 15KV
Dimensions (H x W x D):	5.0 x 3.6 x 0.9 in (127 x 73 x 33 mm)
Weight:	4.6 oz (130 g)
Operating Temperature:	-40°F to 185°F (-40°C to 85°C)
Operating Humidity:	0 to 90% Non-condensing

■ CONNECTIONS

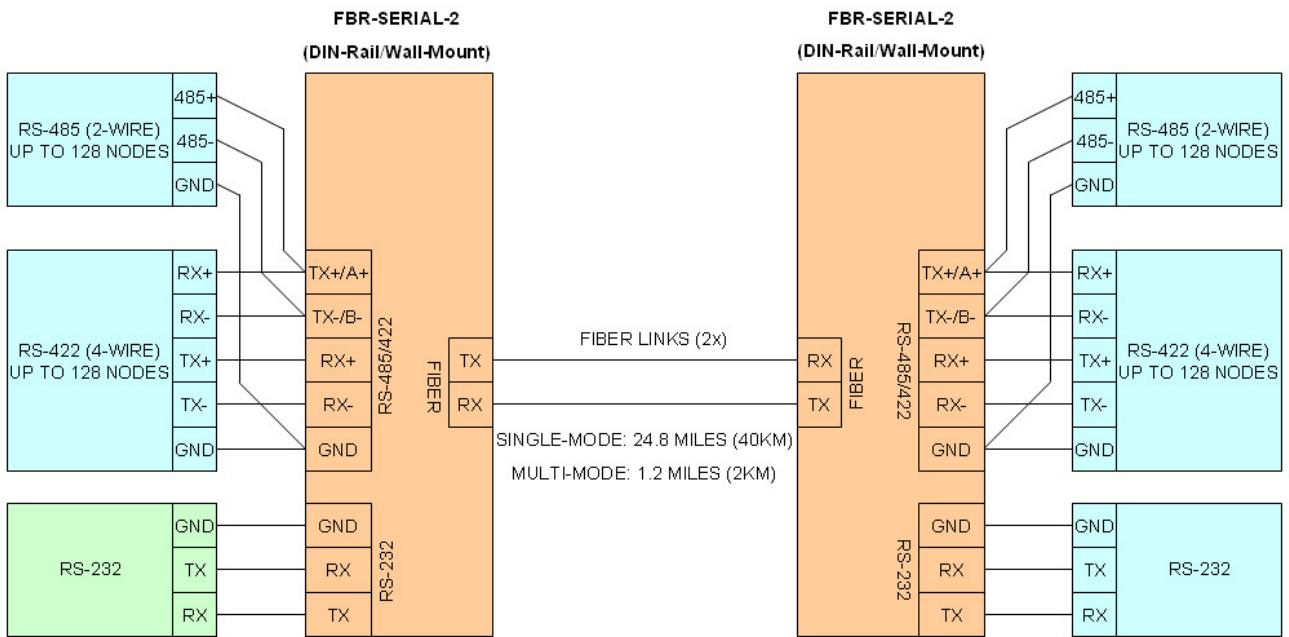

NOTE: CONNECT ONE DATA TYPE AT A TIME

NOTE: CONNECT ONE DATA TYPE AT A TIME

FIGURE 1: FBR-SERIAL-2 CONNECTION DIAGRAM

■ INSTALLATIONS

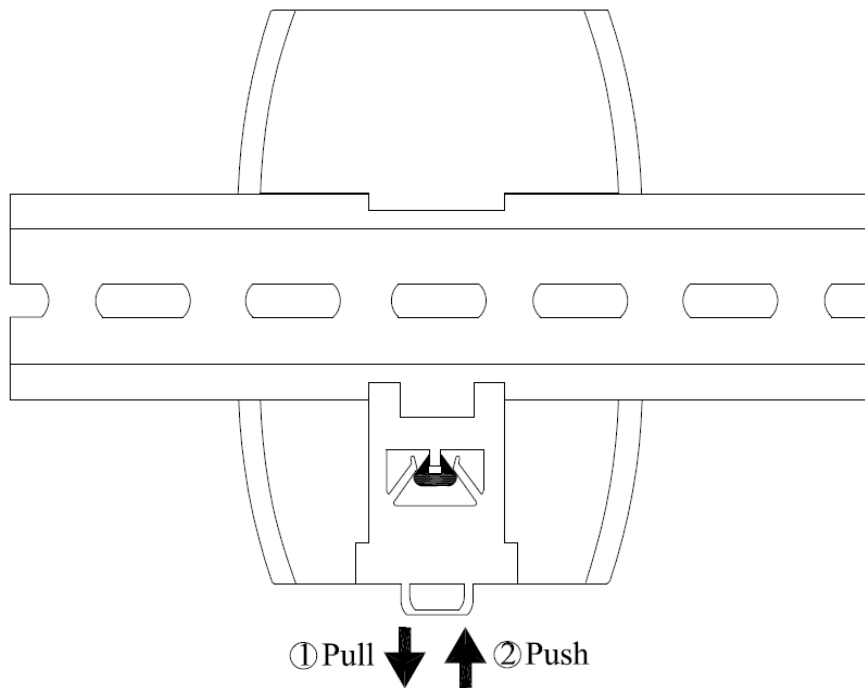

FIGURE 2: DIN-RAIL MOUNTING

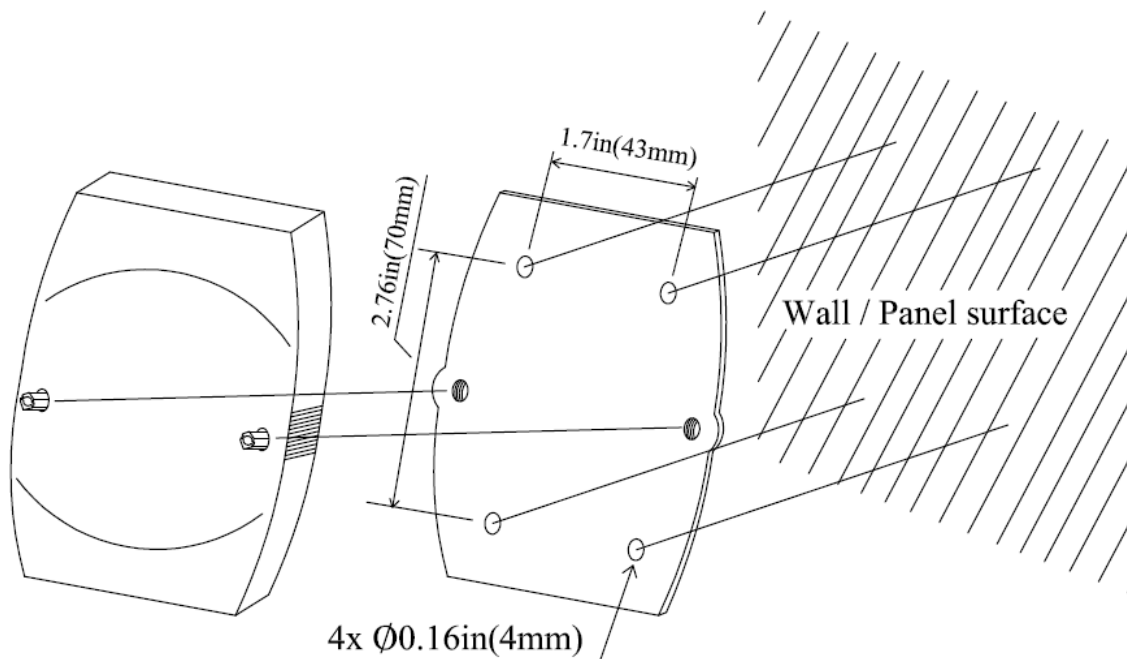

FIGURE 3: WALL/PANEL MOUNTING

■ LED INDICATIONS

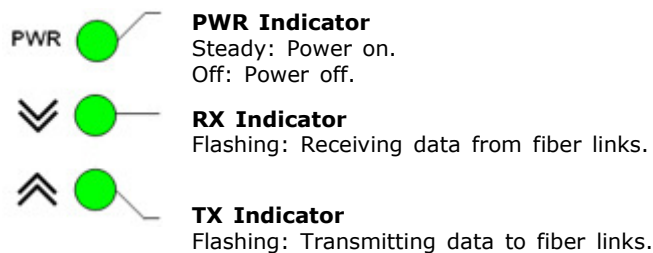

FIGURE 4: LED INDICATIONS

■ TROUBLESHOOTING

- Make sure the Power LED is ON and the RX & TX LEDs are OFF when there is no data communication.
- Check the connections according to the above "CONNECTIONS" diagram (Figure 1).
- Perform a loopback test by using CommFront's 232Analyzer software:
 - 1) Connect "Fiber TX" to "Fiber RX" by using a fiber optic patch cord cable and connect the PC's RS-232 (or RS-485/422) to FBR-Serial-2 according to the above "CONNECTIONS" diagram.
 - 2) Send commands from the 232Analyzer software. You should receive an echo of the commands sent. By performing a simple loopback test like this, you can test both the COM port and the fiber optic module. This is very helpful when you are in doubt about the performance of your converter.